

CODING SYSTEM

■ Coding System

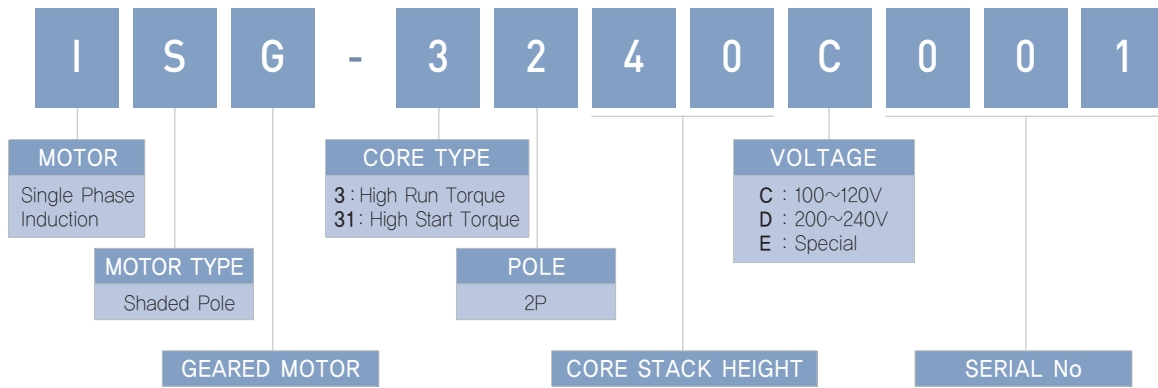

■ Typical Geared Motor Construction

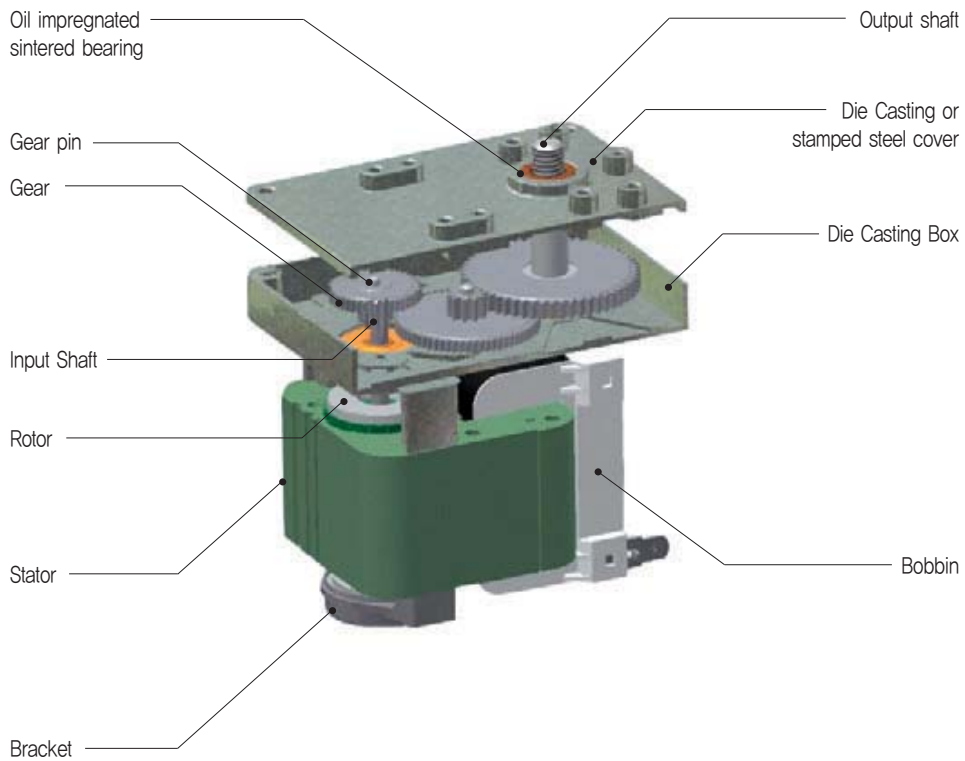

■ Comparison of torque characteristics (3 Core & 31 Core)

Customer should be provided the correct specification (torque and speed, operation condition) for motor required a set. According with these conditions, motor manufacturer will design suitable input torque and gear ratio. Shaded pole motor operates with single direction by AC voltage and also is low-efficient motor, but make a advantage of size and price area, and applied to various set.

■ MODEL CHARACTERISTICS

Unit Conversion : 1kgf-cm = 0.1N-m

TYPE		i						ii						
		Continuous(S1)						Intermittent(S2 15min)						
		Ts		Tr		Tb		Ts		Tr		Tb		
		kgf-cm	N-m	kgf-cm	N-m	kgf-cm	N-m	kgf-cm	N-m	kgf-cm	N-m	kgf-cm	N-m	
A	3 Core	15	0.05	0.005	0.085	0.0085	0.10	0.010	0.10	0.010	0.170	0.0170	0.20	0.020
B		20	0.07	0.007	0.128	0.0128	0.15	0.015	0.15	0.015	0.255	0.0255	0.30	0.030
C		25	0.10	0.010	0.170	0.0170	0.20	0.020	0.20	0.020	0.340	0.0340	0.40	0.040
D		30	0.12	0.012	0.213	0.0213	0.25	0.025	0.25	0.025	0.425	0.0425	0.50	0.050
E		40	0.15	0.015	0.298	0.0298	0.35	0.035	0.30	0.030	0.595	0.0595	0.70	0.070
F		50	0.20	0.020	0.383	0.0383	0.45	0.045	0.40	0.040	0.680	0.0680	0.80	0.080
G	31 Core	15	0.15	0.015	0.038	0.0038	0.15	0.015	0.30	0.030	0.075	0.0075	0.30	0.030
H		20	0.20	0.020	0.050	0.0050	0.20	0.020	0.40	0.040	0.100	0.0100	0.40	0.040
I		25	0.25	0.025	0.063	0.0063	0.25	0.025	0.50	0.050	0.125	0.0125	0.50	0.050
J		30	0.30	0.030	0.075	0.0075	0.30	0.030	0.60	0.060	0.150	0.0150	0.60	0.060

■ N-T CURVE CHARACTERISTICS

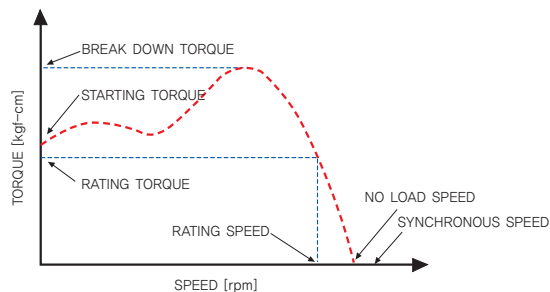

3 Core type Speed-Torque Characteristics

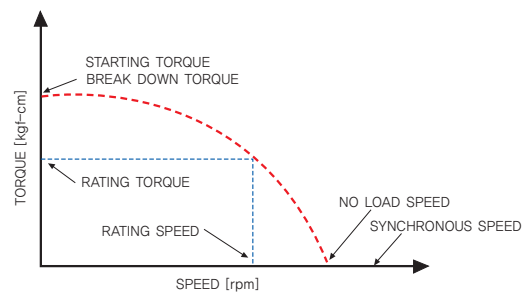

31 Core type Speed-Torque Characteristics

Note)

1. T_b : Break Down Torque, T_s : Starting Torque, T_r : Rating Torque(About Max Efficiency)
2. Geared Motor Output Torque = Motor Torque×Gear Ratio×Gears Step(90%)
Ex) Motors(C-i) + Gear Ratio(1/192) = $0,01 \times 192 \times 0,9^3 = 1,399$ N-m(T_s)
3. Motor Specification Data may be largely differed according with Duty Type and Cooling methods.
4. If fan installed, Motor output canbe increased approximately 20%.
5. Refer to Motor Specification Data above. (Contact with agency or R&D for development)
6. Geared Motor Torque can be used within maximum permissible torque of GearBox. (Refer to 'Maximum Permissible Torque of Gear Box' table)

CHARACTERISTICS

Torque Conversion Chart

	lb-ft	lb-in	oz-in	Dyne-cm	Nm	Ncm	Kpm(kgfm)	gcm
lb-ft	1	12	192	1.356×10^7	1.356	1.356×10^2	0.1383	1.356×10^4
lb-in	8.333×10^{-2}	1	16	1.1298×10^6	0.113	11.3	1.1152×10^{-2}	1.152×10^3
oz-in	5.208×10^{-3}	6.250×10^{-2}	1	7.062×10^4	7.062×10^{-3}	0.7062	7.201×10^{-4}	72.01
Dyne-cm	7.376×10^{-1}	8.851×10^{-7}	1.416×10^{-5}	1	10^{-7}	10^{-5}	1.0197×10^{-8}	1.0197×10^{-3}
Nm	0.7376	8.8509	1.4161×10^2	10^7	1	10^2	0.10197	1.0197×10^4
Ncm	7.376×10^{-3}	8.8509×10^{-2}	1.4161	10^5	10^{-2}	1	1.0197×10^{-3}	0.10197
Kpm(kgfm)	7.233	86.79	1.389×10^3	9.8067×10^7	9.8066	980.665	1	10^5
gcm	7.233×10^{-5}	8.680×10^{-4}	1.389×10^{-2}	980.67	9.8066×10^{-5}	9.8066×10^{-3}	10^{-5}	1

How to Select a Geared Motor

ELECTRICAL CONSIDERATION

Determine the nominal or rated voltage and frequency. Also, the high and low voltage conditions must be addressed, as there is a direct relationship between voltage, motor performance and winding temperature.

TORQUE

Torque performance is normally rated in newton meters (or inch-pounds) of starting, running, or breakdown torque. It is important to determine if the torque load is immediate, gradual, or of shock nature. This decision is essential for determination of the proper motor, gearing and gearcase configuration. All variable loads and worst case scenarios of your application must be considered.

Maximum Permissible Torque of Gear Box

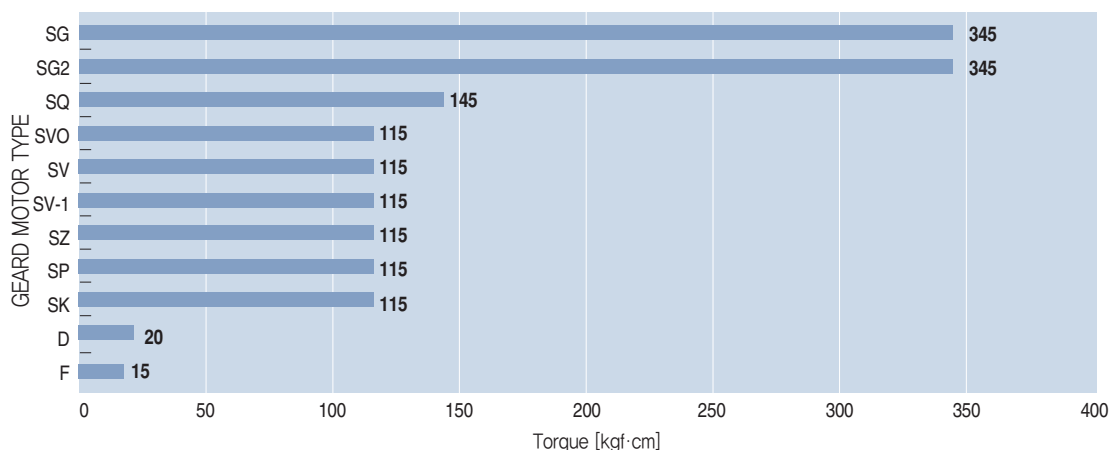

Gear Box & Motor Combinations

TYPE	SG	SG2	SQ	SVO	SV	SV-1	SZ	SP	SK	D	F
31 Core		●	●	●			●	●			
3 Core	●	●	●	●	●	●	●	●	●	●	●
FAN ASS'Y	●	●	●	●	●	●	●	●	●	●	●
CLUTCH BRAKE	●	●	●	●	●	●	●	●	●	●	●

* Mounting of clutch brake can apply the ISG-3 TYPE only.(CORE STACK 25 Min.)

TORQUE MEASUREMENT

There are two commonly used methods of measuring torque if you are unsure of your torque requirements:

1 String and Pulley Method

Affix a pulley to the shaft of the machine to be driven (see fig. A). Secure one end of a cord to the outer surface of the pulley and wrap the cord around it a number of times. Tie the other end of the cord to a spring scale. Pull on the scale until the shaft turns. The force, in pounds indicated on the scale, multiplied by the radius of the pulley gives the torque or twisting rate in kgf-cm. Depending on the application, and if used carefully, this method is reliable in determining both starting and running torque.

When the pulley begins to turn, starting torque is indicated. The average running torque can be determined if a long enough string is used.

When the torque characteristics of the machine vary in different parts of the operating cycle, the starting torque must be determined at the point where the motor or Geared Motor will “see” the highest resistance (torque) to starting.

■ Simple "string and pulley" method of torque measurement (Torque = Force reading on spring scale x radius of the pulley)

2 Wrench Method

A simple torque wrench can be applied to the shaft of the machine to be driven. Turn the wrench as you would an ordinary pipe wrench and, when the shaft begins to rotate, read the value (kgf-cm) on the torque wrench gauge. The observed value represents the torque required to start the machine. This method is normally limited to obtaining starting torque or peak torque values, as it is unsafe and difficult to attempt to continuously rotate a torque wrench.

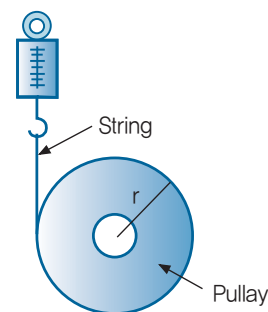

[Fig A]

OUTPUT SPEED

Speed (RPM) is rated in a full load or free running condition. The rated frequency, if applicable, of the associated voltage will affect overall output speed. The performance of the Geared Motor can be effected with the use of dual frequency AC coils.

$$\text{Synchronous revolutions per minutes} = \frac{120f}{p} [\text{rpm}]$$

f : Frequency of a power source [Hz]
 p : Number of poles in a motor
 120 : Constant

ENVIRONMENT

Environmental areas of concern should be storage, condition when not running and maximum usage. Numerous applications involve caustic, dusty, humid or extreme temperature environments. Please consider all conditions within the specific environment.

DUTY CYCLE

This specification is critical in determining the endurance of the gearmotor as it relates to the total product and application. The most important criteria are “time-on” and “time-off” in actual seconds, minutes, or hours. Also important is the total number of cycles when considering Geared Motor design.

FORCES ON SHAFT

An extensive radial load may dictate a larger shaft diameter for increased bearing surface. Extreme condition(s) may dictate needle bearings. Light axial loads require the use of appropriate thrust washers. The Geared Motor output shaft may not support excessive axial loads.

CHARACTERISTICS

SHAFT ROTATIONS, DIMENSIONS AND MACHINING

Shaft Rotations must be considered carefully especially when reversing motors are being used. Reversibility is more costly and involves additional circuitry. With uni-directional gearmotors the direction of rotation is specified from the shaft end of a single shaft gearmotor. With dual shaft gearmotors, the direction of rotation is specified from either the cover of the gearcase or the motor side of the gearcase. Output shaft diameter, length and machining should be determined with the advice of your SPG.Co.Ltd Sales team .

MOTOR PROTECTION

From a mechanical standpoint, first determine if a stalled condition is a normal mode of operation, occasional or unintentional. Gearcase and motor designs are greatly influenced by this criteria. There are two basic types of recognized locked rotor AC motor protection, recognized by the U.L. and C.S.A.

1 Thermal Protection

Utilizes a thermal protector located on the motor coil. Should a coil reach a maximum temperature as prescribed in agency standards (Class A, Class B, etc.) the thermal protector will open, shutting off current to the motor winding. Tripping of the thermal protector should be considered unusual.

2 Impedance Protection

This type relies on the inherent total impedance of the stator/coil combination to dissipate excessive winding temperatures.

MOUNTING STYLE AND POSITION

Design considerations will be effected by the position of the Geared Motor in the application. The mounting position may affect shaft loading or the performance of the optional motor brakes. The optimal position for peak performance is a horizontal shaft-mounting configuration.

TECHNICAL ADVICE

■ Glossary of Terms

- ▶ **Ambient** : The temperature and the humidity of the motor surrounding while operating. Generally, the motor is designed to operate in the condition of the surrounding temperature from $-10^{\circ}\text{C}\sim 40^{\circ}\text{C}$ ($14^{\circ}\text{F}\sim 104^{\circ}\text{F}$) and the surrounding humidity below 80% (no dew condensation).
- ▶ **Overheating Protection** : When motor operates, due to the overload or the input current, the temperature of the motor rises. So in order to prevent overheating, the motor includes built-in automatic-return type T/P (thermal protector). The T/P disconnects the power when the temperature rises and reconnects when the motor cools down automatically.
- ▶ **Thermal Protector** : The device which automatically disconnects the power of the motor when there is abrupt temperature rise due to overload or other operation defect.
- ▶ **Torque** : The tendency of a force to rotate an object about an axis, fulcrum or pivot.
- ▶ **Starting Torque** : The torque that the motor develop when it starts at zero speed.
- ▶ **Stall Torque (=Breakdown Torque)** : The maximum torque of the operating motor. The torque increases more than the stall torque, the motor stops or the speed changes.
- ▶ **Rated Torque** : The torque of the motor at the rated speed (rpm).
- ▶ **Braking** : The mechanical and/or electrical mechanism that reduces or stops instantly or reduces the speed to control the overrun. The degree of holding torque will change as the selected brake type.
- ▶ **Coupling Load to Shaft** : Consider the form of the coupling with the configuration and machining of the output shaft. The superlative design is to locate the load nearest to the gear-case output bearing.
- ▶ **Duty Cycle** : The cycles between operation and stop
- ▶ **Full Load** : The minimum speed of the induction motor operated under rated load output torque. Full load changes by the rating and characteristics of the specific motor and is less than the synchronous speed.
- ▶ **Full Load Current** : The current generated by the motor operated at the rated output torque and the voltage.
- ▶ **Hertz (Hz)** : Frequency of AC power in cycles per second. Generally in Korea, it is 60Hz, but the overseas, it changes.
- ▶ **Impedance Protected** : Under locked rotor or stalled condition, motor is thermally protected from the motor impedance to prevent burnout per UL standard No. 1004-2.
- ▶ **Motor Type** : Classification of the motor under its' characteristics and power specified. For example, 3 type or 31 type of shaded core.
- ▶ **Mounting** : The position of the mounting may affect the shaft loading and the performance of the optional motor brake.
- ▶ **Output Speed** : Speed rated as revolution per minute in a full load or free operation condition. The rated frequency of the voltage affects the overall output speed.
- ▶ **Overhung Load** : The load on the motor or gearhead output shaft in the radial direction. The bearing and the shaft must support this load while transmitting power.
- ▶ **Rotation** : Direction of the shaft rotating in clockwise (CW), counterclockwise (CCW) or reversing.
- ▶ **Shaded Pole** : The economical motor consisting of steel laminations, electrical field coil, small copper shading coil and the rotor. SPG provides high starting and high running torque models.
- ▶ **Sleeve Bearing** : Used when low noise level is required. Can be mounted in any position, shaft-up, down, left and right.
- ▶ **Temperature Rise** : The temperature above the surrounding when the motor is operating.
- ▶ **Alternating Current** : The movement of electric charge periodically reverses direction.
- ▶ **Direct Current** : The unidirectional flow of electric charge.

CODING SYSTEM

■ Coding System

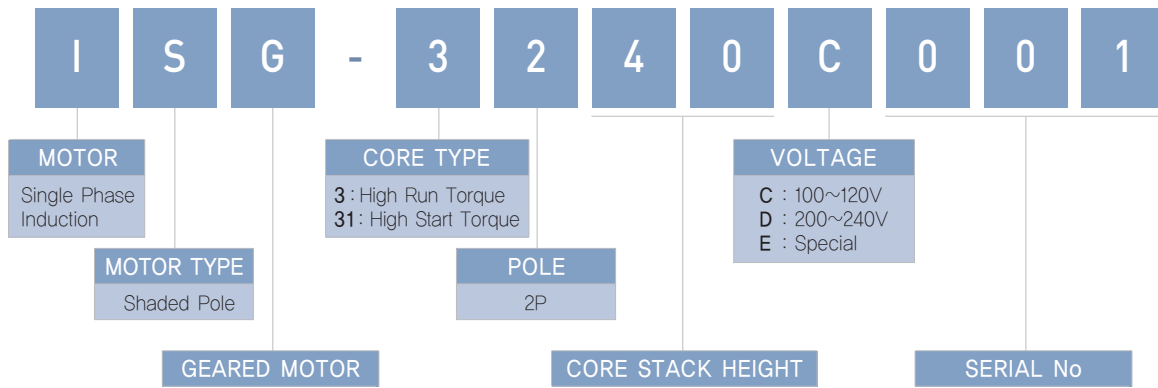

■ Typical Geared Motor Construction

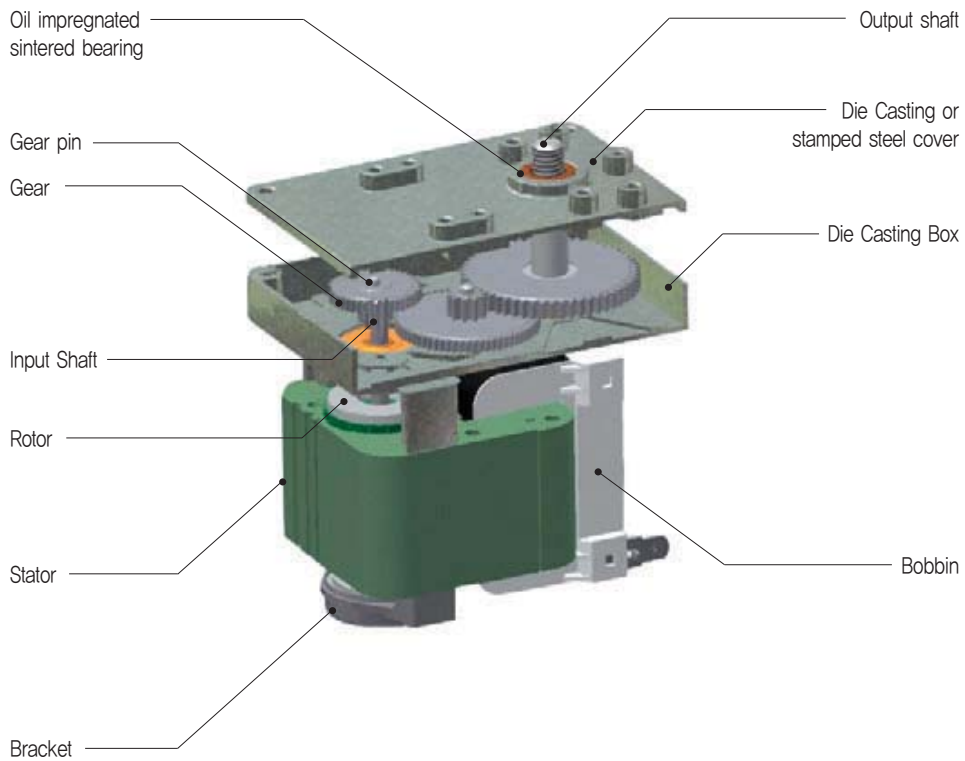



GEAR BOX SG2 Series motor ISG-3 Type

Maximum permissible torque of gear box : 345kgf-cm Max.

DIMENSION

UNIT : mm[inch]

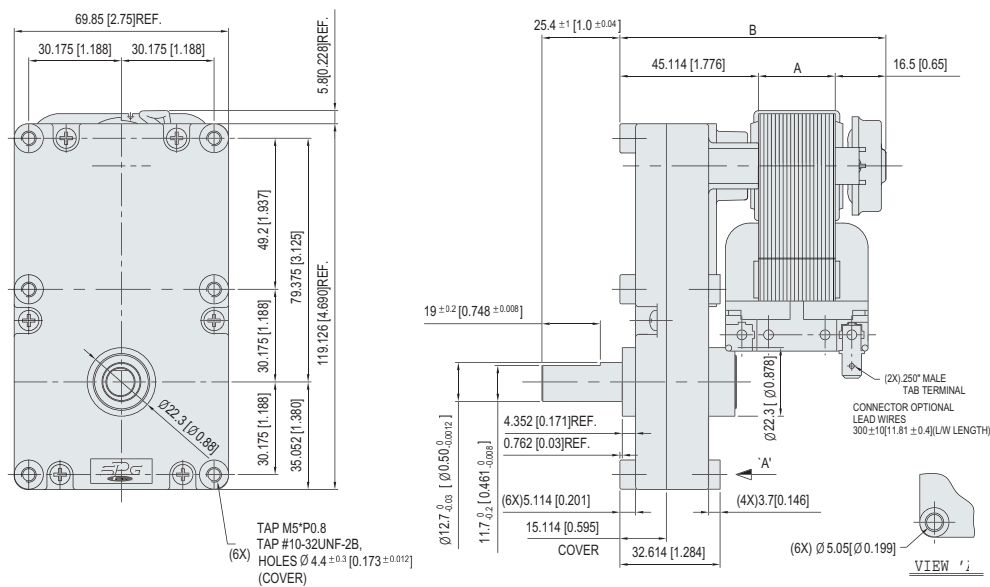

11
Maximum permissible torque of gear box

Type	A		B	
ISG-3215	15	0,591	76,614	3,016
ISG-3220	20	0,787	81,614	3,213
ISG-3225	25	0,984	86,614	3,410
ISG-3230	30	1,181	91,614	3,607
ISG-3240	40	1,575	101,614	4,001
ISG-3250	50	1,969	111,614	4,394

REDUCTION RATIOS & OUTPUT SPEED

Ratio	395.7	1218.1	1412.5	1620.7	1709.9	3238.2	
Gear Steps	4			5			
Output Speed(Ref.)	@ 60Hz	9,1	3,0	2,5	2,2	2,1	1,1
	@ 50Hz	7,6	2,5	2,1	1,9	1,8	0,9

- Depending on Motor spec and Gear Box reduction ratio combination, Output speed and Torque specification can differ.
- If Cooling Fan and Clutch installed, Refer to Accessory Part. (Due to Fan and Clutch installation, motor's length is extended).
- Please contact our sales department regarding other gear ratio.
- The speed is calculated by dividing the motors synchronous speed (50Hz : 3,000rpm, 60Hz : 3,600rpm) by the gear ratio.

CODING SYSTEM

■ Coding System

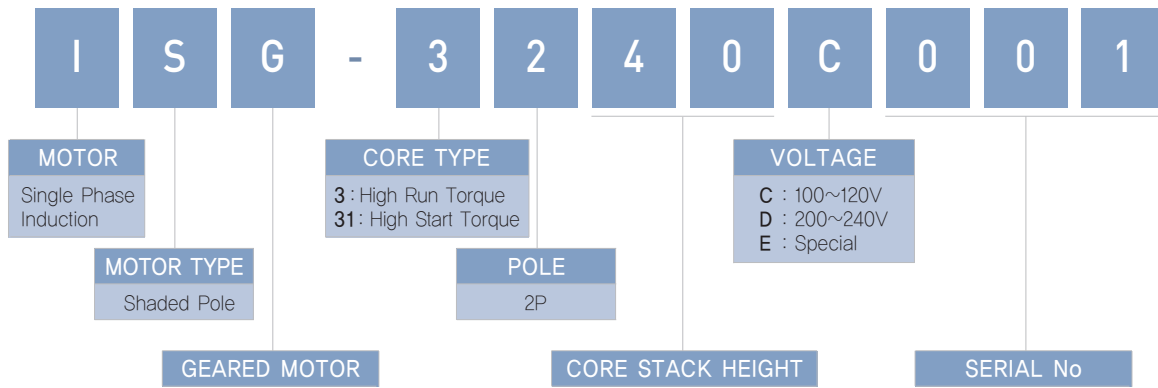

■ Typical Geared Motor Construction

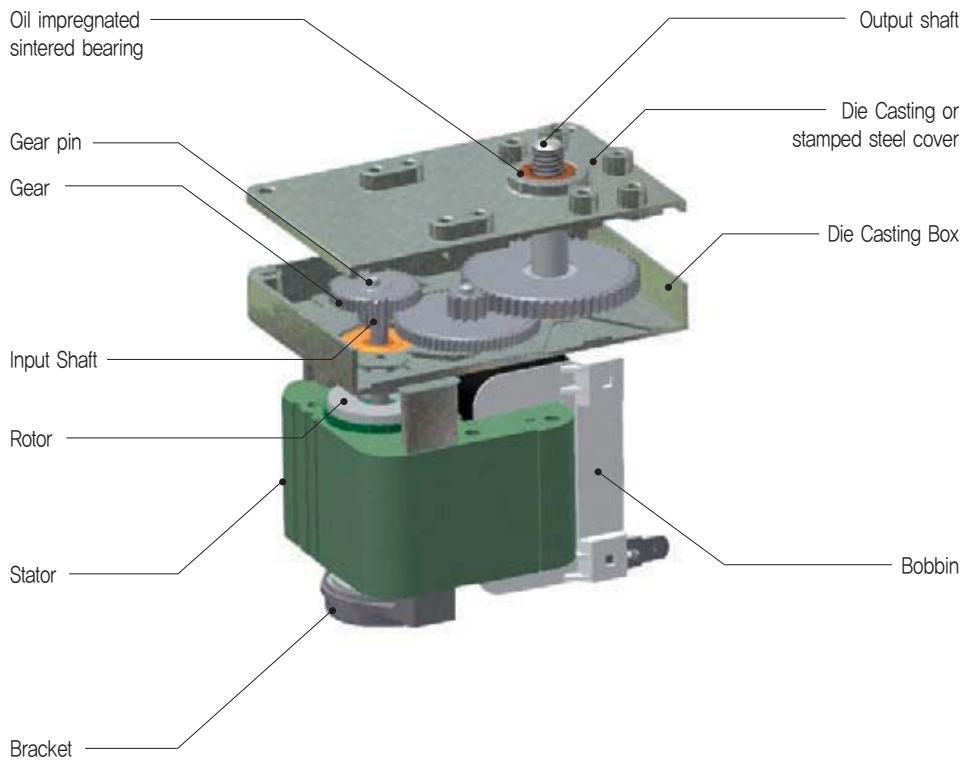



GEAR BOX SV Series motor ISG-3 Type

Maximum permissible torque of gear box : 115kgf-cm Max.

DIMENSION

UNIT : mm[inch]

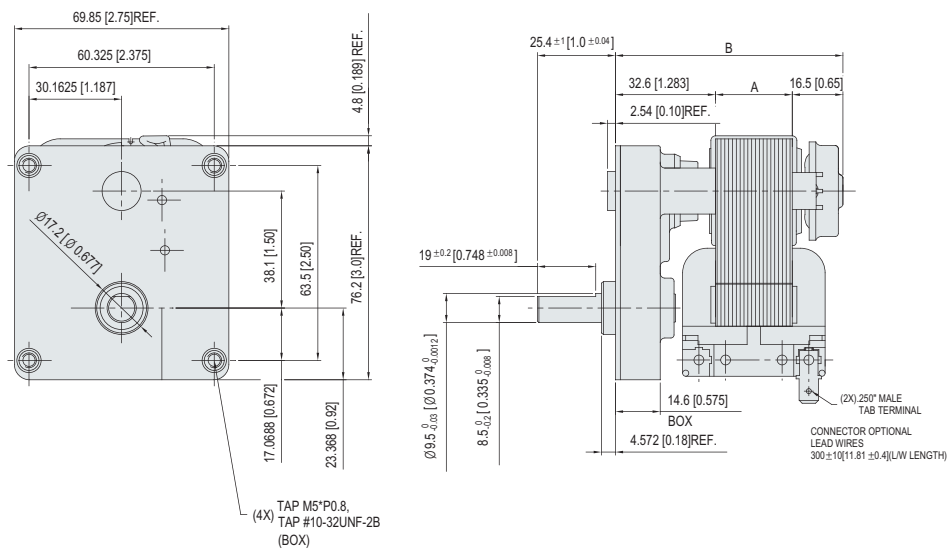

Maximum permissible torque of gear box | 16

Type	A		B	
ISG-3215	15	0.591	64.1	2.524
ISG-3220	20	0.787	69.1	2.720
ISG-3225	25	0.984	74.1	2.917
ISG-3230	30	1.181	79.1	3.114
ISG-3240	40	1.575	89.1	3.508
ISG-3250	50	1.969	99.1	3.902

REDUCTION RATIOS & OUTPUT SPEED

Ratio	21.2	64.9	130.3	168	
Gear Steps	3				
Output Speed(Ref.)	@ 60Hz	169.8	55.5	27.6	21.4
	@ 50Hz	141.5	46.2	23.0	17.9

- Depending on Motor spec and Gear Box reduction ratio combination, Output speed and Torque specification can differ.
- If Cooling Fan and Clutch installed, Refer to Accessory Part. (Due to Fan and Clutch installation, motor's length is extended).
- It is stamped steel cover type.
- Please contact our sales department regarding other gear ratio.
- The speed is calculated by dividing the motors synchronous speed (50Hz : 3,000rpm, 60Hz : 3,600rpm) by the gear ratio.



GEAR BOX SV-1 Series motor ISG-3 Type

Maximum permissible torque of gear box : 115kgf-cm Max.

DIMENSION

UNIT : mm[inch]

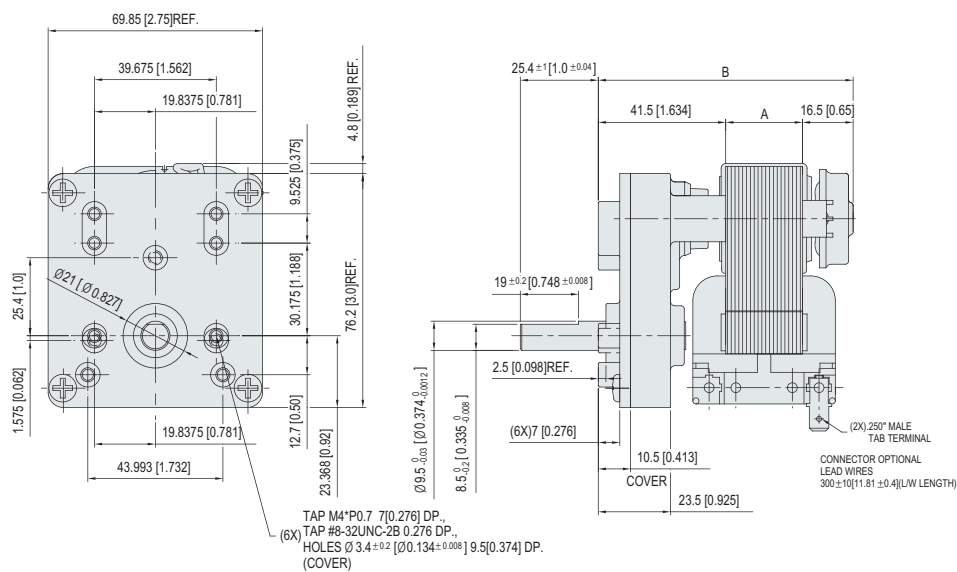

Type	A		B	
ISG-3215	15	0.591	73.0	2.874
ISG-3220	20	0.787	78.0	3.071
ISG-3225	25	0.984	83.0	3.268
ISG-3230	30	1.181	88.0	3.465
ISG-3240	40	1.575	98.0	3.858
ISG-3250	50	1.969	108.0	4.252

REDUCTION RATIOS & OUTPUT SPEED

Ratio	21.2	64.9	130.3	168	
Gear Steps	3				
Output Speed(Ref.)	@ 60Hz	169.8	55.5	27.6	21.4
	@ 50Hz	141.5	46.2	23.0	17.9

- Depending on Motor spec and Gear Box reduction ratio combination, Output speed and Torque specification can differ.
- If Cooling Fan and Clutch installed, Refer to Accessory Part. (Due to Fan and Clutch installation, motor's length is extended).
- Please contact our sales department regarding other gear ratio.
- The speed is calculated by dividing the motors synchronous speed (50Hz : 3,000rpm, 60Hz : 3,600rpm) by the gear ratio.

CODING SYSTEM

■ Coding System

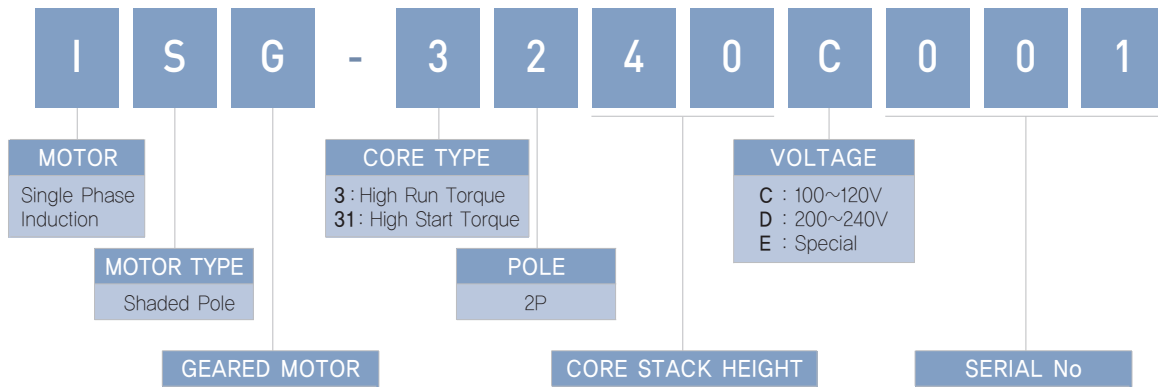

■ Typical Geared Motor Construction

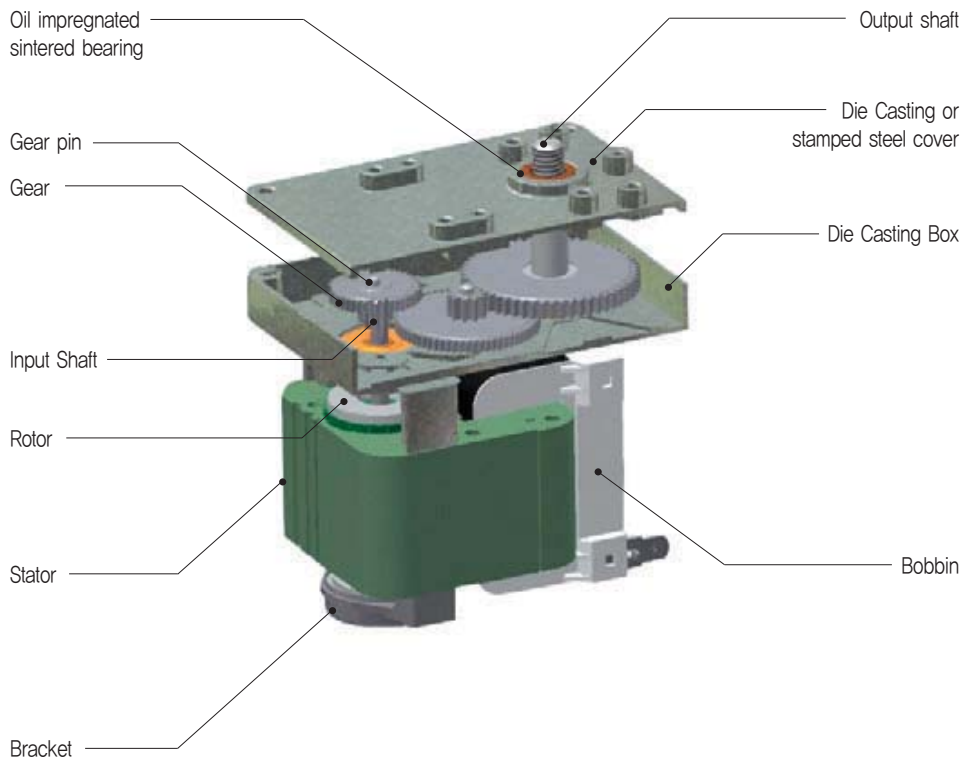



GEAR BOX SQ Series motor ISG-3 Type

Maximum permissible torque of gear box : 145kgf-cm Max.

DIMENSION

UNIT : mm[inch]

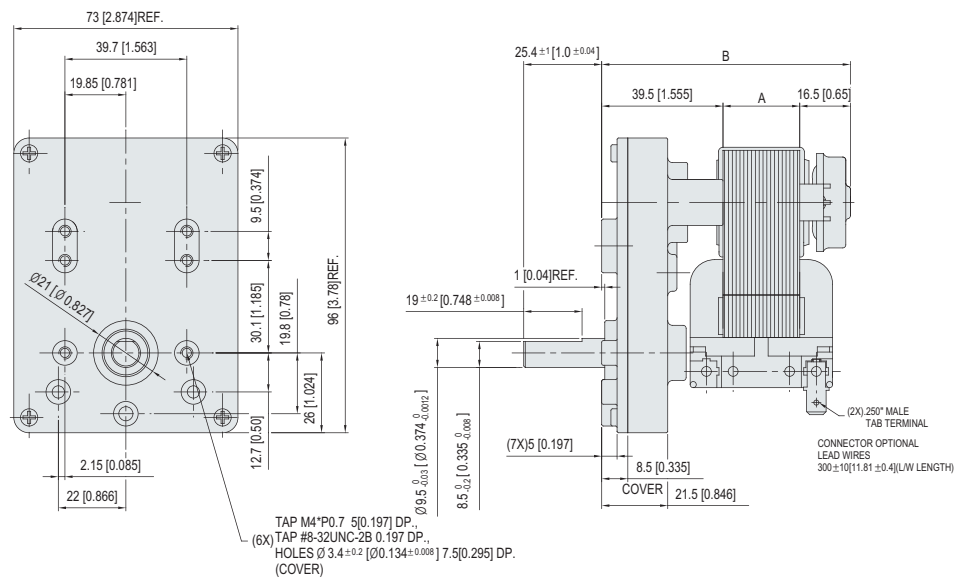

Maximum permissible torque of gear box | 20

Type	A		B	
ISG-3215	15	0.591	71	2,795
ISG-3220	20	0,787	76	2,992
ISG-3225	25	0,984	81	3,189
ISG-3230	30	1,181	86	3,386
ISG-3240	40	1,575	96	3,780
ISG-3250	50	1,969	106	4,173

REDUCTION RATIOS & OUTPUT SPEED

Ratio	47.9	57.2	68.4	75.3	116.5	124.9	144	192.1	210.8	
Gear Steps	3								4	
Output Speed(Ref.)	@ 60Hz	75.2	62.9	52.6	47.8	30.9	28.8	25.0	18.7	17.1
	@ 50Hz	62.6	52.4	43.9	39.8	25.8	24.0	20.8	15.6	14.2

- Depending on Motor spec and Gear Box reduction ratio combination, Output speed and Torque specification can differ.
- If Cooling Fan and Clutch installed, Refer to Accessory Part. (Due to Fan and Clutch installation, motor's length is extended).
- Please contact our sales department regarding other gear ratio.
- The speed is calculated by dividing the motors synchronous speed (50Hz : 3,000rpm, 60Hz : 3,600rpm) by the gear ratio.



GEAR BOX SQ Series motor ISG-31 Type

Maximum permissible torque of gear box : 145kgf-cm Max.

DIMENSION

UNIT : mm[inch]

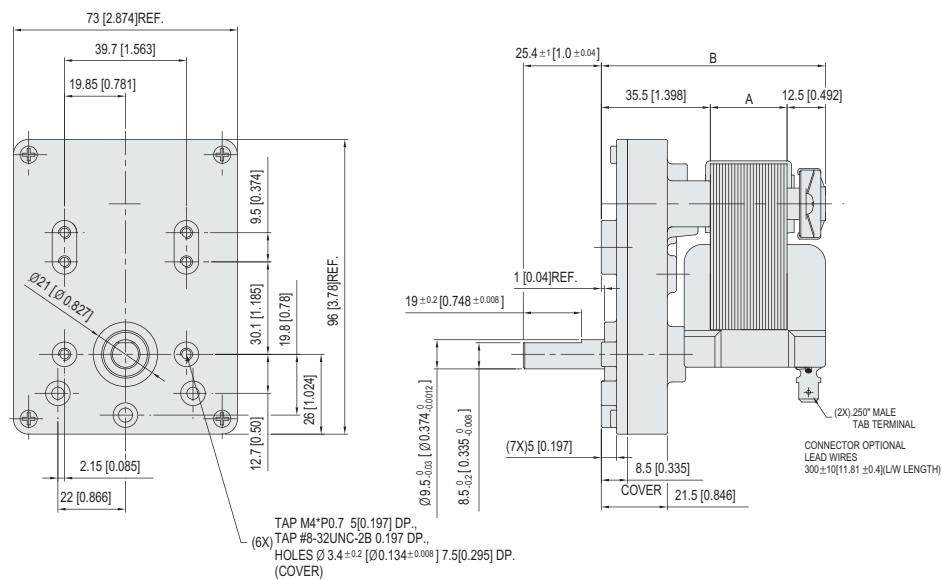

Type	A		B	
ISG-31215	15	0.591	63	2,480
ISG-31220	20	0.787	68	2,677
ISG-31225	25	0.984	73	2,874
ISG-31230	30	1,181	78	3,071

REDUCTION RATIOS & OUTPUT SPEED

Ratio	124.9	192.1	443.7	517.6	582.3	664	844.8	1240.2	
Gear Steps	3			4					
Output Speed(Ref.)	@ 60Hz	28.8	18.7	8.1	7.0	6.2	5.4	4.3	2.9
	@ 50Hz	24.0	15.6	6.8	5.8	5.2	4.5	3.6	2.4

- Depending on Motor spec and Gear Box reduction ratio combination, Output speed and Torque specification can differ.
- If Cooling Fan installed, Refer to Accessory Part, (Due to Fan installation, motor's length is extended).
- Please contact our sales department regarding other gear ratio.
- The speed is calculated by dividing the motors synchronous speed (50Hz : 3,000rpm, 60Hz : 3,600rpm) by the gear ratio.

CODING SYSTEM

■ Coding System

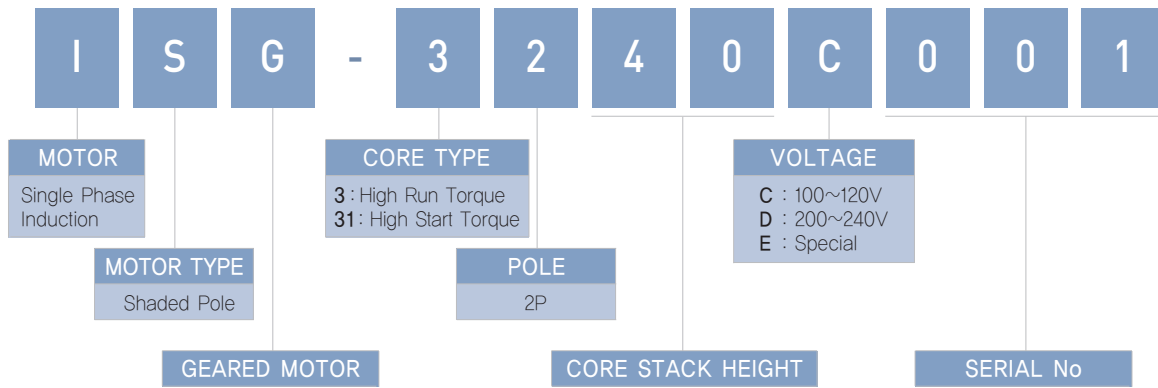

■ Typical Geared Motor Construction

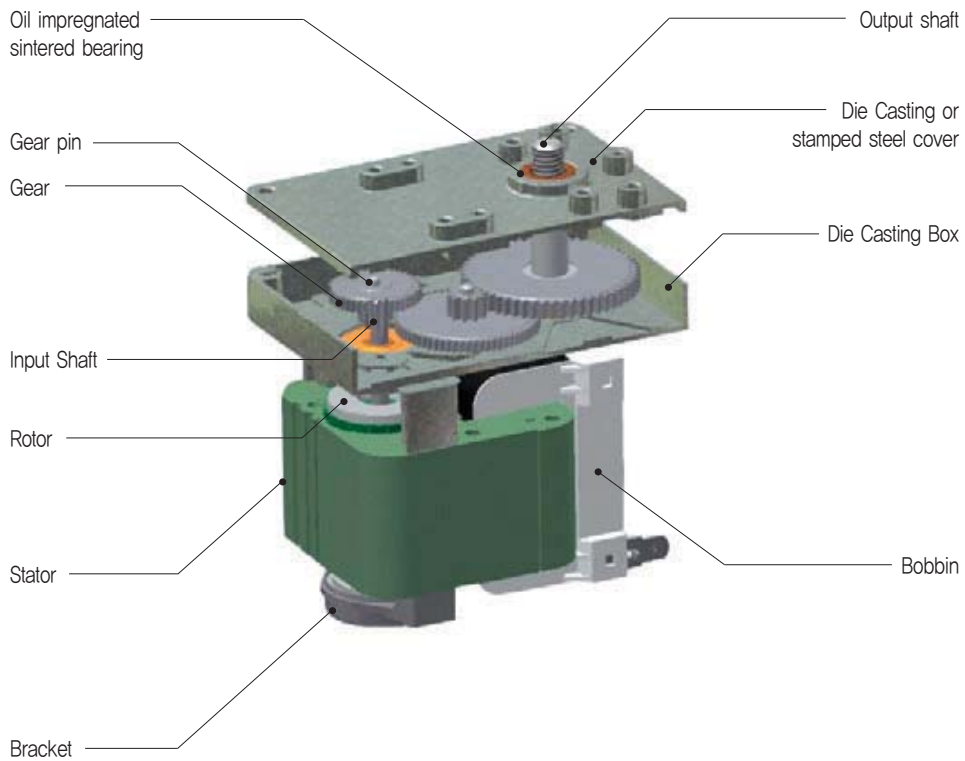



ACCESSORY CLUTCH BRAKE motor ISG-3 Type

DIMENSION

UNIT : mm[inch]

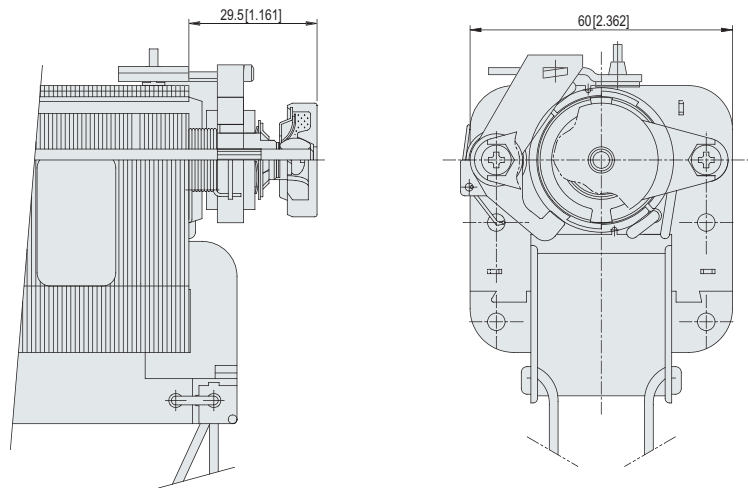

- It is a dedicated ISG-3 TYPE.(CORE STACK 25 Min.)
- If Clutch installed, Note that it during designing, as overall length for motor increases.
- Warranty service Life : MIN. 200-thousand cycle.
- Contact with us for specification of other product.



ACCESSORY FAN: SF-0568CW



ACCESSORY FAN: SF-0568CCW

DIMENSION

UNIT : mm[inch]

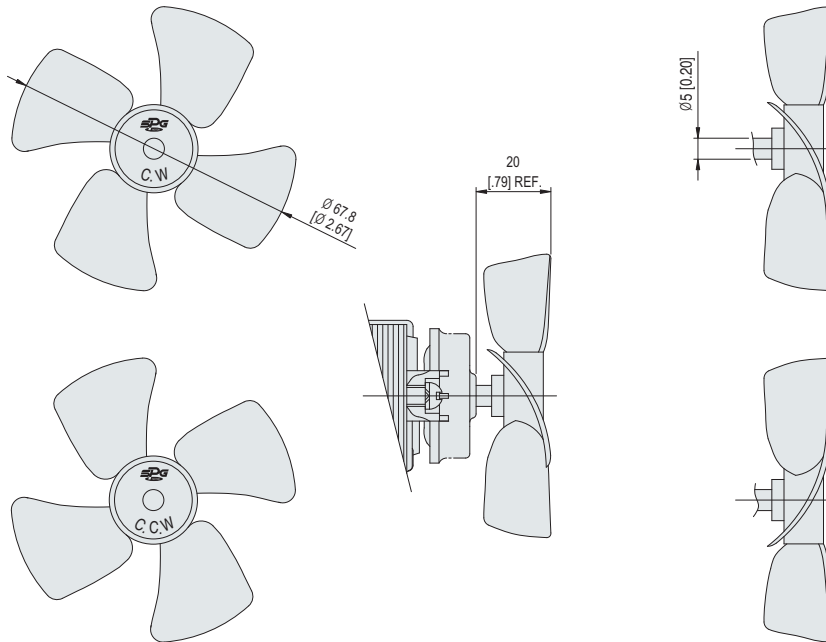

- It is installed in the a set having trouble for temperature increase, or motor required continuous operation.
- Above fan is the unit for protect motor's overheating, cooling capability of the fan can vary according with ambient temperature and conditions.
- After installing the fan, motor rear section is increased approximately 20mm [], Proper space should be ensured within the set for operating the fan.
- Direction of applied fan can vary according with the stage number of reduction speed.